

Solution to meet your challenges

Vaisala AviMet® AWOS Automated Weather Observing System

Vaisala AviMet® Automated Weather Observing System (AWOS) is a fully configurable airport weather system that collects, processes, and visually displays meteorological data.

The AWOS help pilots and aviation personnel make critical decisions by providing continuous, real-time reports on airport weather conditions. AWOS weather reports are made available to airport personnel via displays on operator terminals, and to pilots via high quality, digitized voice transmissions using a VHF frequency, a VOR, a NDB or an existing ATIS frequency. AWOS reports are also available by telephone for flight planning.

In addition to measuring basic weather parameters, the AWOS can be customized to detect runway condition and also the more problematic weather phenomena such as wind shear and lightning.



Features / Benefits

- Compliant to ICAO standards and recommendations as well as WMO regulations
- Fully configurable and modular
- Scalable with an open system architecture
- Customized user interfaces
- Superior data accuracy and consistency
- Basic set of parameters observed: wind speed and direction, barometric pressure, relative humidity, cloud height, horizontal visibility
- Type and amount of sensors can be adjusted based the airport's needs
- Guaranteed maximum data availability and reliability by duplicated central data units
- Runs on Windows® environment
- Seamless integration of meteorological data into any ATC, airport-wide service and maintenance systems, and other meteorological systems
- Supports the following ICAO and WMO defined reports:
 - METAR and SPECI
 - MET REPORT and SPECIAL
 - TAF
 - SIGMET- AIRMET
 - GAMET
 - AD WRNG
 - SNOWTAM
 - SYNOP
 - CLIMAT
- Part of AviMet® technology platform

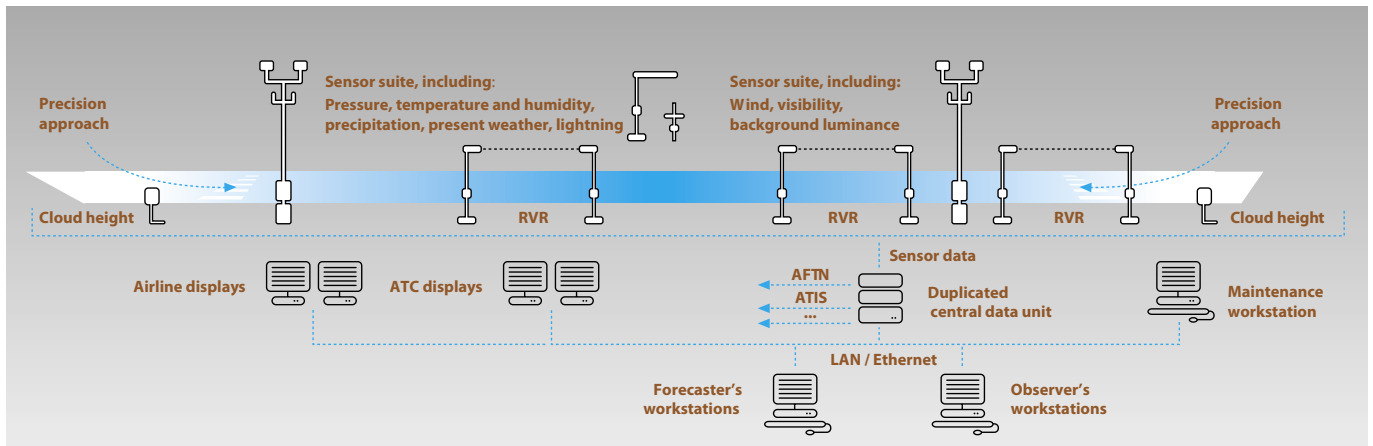

A typical Vaisala AviMet AWOS consists of the field sensors, central data unit(s), communication interfaces and different workstation types.

System overview

A minimum installation of Vaisala AviMet® AWOS consists of sensors, communications equipment, and one Central Data Unit (CDU) which works also as a workstation and runs the software applications. The minimum system can be expanded without any limits to the system size. Components of a typical AWOS:

- Central data unit (CDU) with housing
- Communications equipment
- User workstations
- Remote Control and Maintenance workstation
- Digital displays
- Printers for data and alarms
- Field sensors, associated power and signal cabling, and installation accessories
- UPS for the Central Data Unit(s)

All critical functions of the system can be duplicated to ensure uninterrupted flow of data.

Software architecture

The AWOS software consists of the CDU software and the workstation software. The CDU software

performs main operational tasks, and monitors and controls the system operation.

Central data unit

The CDU is the main computer which collects data from the sensors and performs meteorological calculations, generates reports, and continuously carries out diagnostics of the incoming data and the entire system itself. The CDU also stores the measured and calculated data as well as the transmitted reports.

Workstations and displays

The number of different workstation types depends on the system configuration. Each workstation type has a preconfigured workstation environment and includes a different set of applications.

The commonly used workstation types are: Observer workstation, Forecaster workstation, Weather View workstation, and Remote Control and Maintenance workstation. Several display options are available and they can be configured to each user's preference and needs.

Seamless integration

The AviMet® system's open software and system architecture ensure smooth integration of meteorological data into any ATC, airport-wide service and maintenance systems, and other meteorological systems an airport may have. The AviMet® software runs on Windows® environment.

Communication methods

Vaisala AviMet® AWOS is designed to interface by various output communication formats and to meet various communication standards and conventions.

Database

The Vaisala AviMet® AWOS system can contain a relational database for data storing which enables the generation of SYNOP and CLIMAT reports. The users interrogate the data using SQL queries, and the numerical data, generated reports, and graphs can be further distributed or stored.

VAISALA

For more information, visit www.vaisala.com or contact us at aviationsales@vaisala.com

Ref. B210848EN-A ©Vaisala 2009

This material is subject to copyright protection, with all copyrights retained by Vaisala and its individual partners. All rights reserved. Any logos and/or product names are trademarks of Vaisala or its individual partners. The reproduction, transfer, distribution or storage of information contained in this brochure in any form without the prior written consent of Vaisala is strictly prohibited. All specifications - technical included - are subject to change without notice.