

HMT310 Humidity and Temperature Transmitter



The Vaisala HUMICAP® Humidity and Temperature Transmitter HMT310 with the HMT317 probe.

Features/Benefits

- Next-generation Vaisala HUMICAP® Sensor for excellent accuracy and stability
- Full 0 ... 100 %RH measurement, temperature range up to +180 °C (depending on model)
- Small size, easy to integrate
- Insensitive to dust and most chemicals
- NIST traceable

Reliable Vaisala HUMICAP® technology

The HMT310 incorporates the latest-generation Vaisala HUMICAP® Sensor. It offers even more stability and chemical resistance than before. It has a small, pressure-tight probe, HMT317, with optional Swagelok fittings.

The Vaisala HUMICAP® Sensor is a capacitive thin-film polymer sensor. It features high accuracy, excellent long-term stability and negligible hysteresis. It is insensitive to dust, particulate dirt and most chemicals.

Several outputs, one connector

The HMT310 is powered up with 12 ... 35 VDC. It has two analog outputs and an RS-232 serial output. The output signal and the supply

power travel in the same cable, the only cable connected to the unit.

Chemical purge

Chemical purge helps to maintain measurement accuracy between calibration intervals. Chemical purge involves heating the sensor to remove harmful chemicals. The function can be initiated manually or programmed to occur at set intervals.

Optional functions

The following optional functions are available: several probes for various applications, calculated humidity quantities, different mounting kits, sensor protection options and probe cable lengths, warmed probe and sensor heating for high humidity conditions (HMT317), and chemical purge for applications risking an interference with chemicals in the measuring environment.

Technical data

Performance

RELATIVE HUMIDITY

Measurement range	0 ... 100 %RH
Accuracy (incl. non-linearity, hysteresis and repeatability) with	
Vaisala HUMICAP®180	typical applications
Vaisala HUMICAP®180R	typical applications
Vaisala HUMICAP®180C	applications with chemical purge
Vaisala HUMICAP®180RC	and/or warmed probe
at a temperature range of	
+15 ... +25 °C	±1 %RH (0 ... 90 %RH)
	±1.7 %RH (90 ... 100 %RH)
-20 ... +40 °C	±(1.0 + 0.008 x reading) %RH
-40 ... +180 °C	±(1.5 + 0.015 x reading) %RH

Accuracy (incl. non-linearity, hysteresis and repeatability) with	
Vaisala HUMICAP®180L2	applications with demanding chemical environment

at a temperature range of	
-10 ... +40 °C	±(1.0 + 0.01 x reading) %RH
-40 ... +180 °C	±(1.5 + 0.02 x reading) %RH
Factory calibration uncertainty (+20 °C)	±0.6 %RH (0 ... 40 %RH)*
	±1.0 %RH (40 ... 97 %RH)*

* Defined as ±2 standard deviation limits. Small variations possible, see also calibration certificate.

Response time (90 %) for	
Vaisala HUMICAP®180 and	8 s with grid filter, 20 s with grid and steel, netting filter, 40 s with sintered filter
Vaisala HUMICAP®180C at +20 °C in still air	

Response time (90 %) for	
Vaisala HUMICAP®180R and	17 s with grid filter,
Vaisala HUMICAP®180RC at +20 °C in 0.1 m/s air flow	50 s with grid and steel, netting filter, 60 s with sintered filter

TEMPERATURE

HMT317 (vapor tight) -70 ... +180 °C

Other probes available by request

Accuracy over temperature range (see graph below)

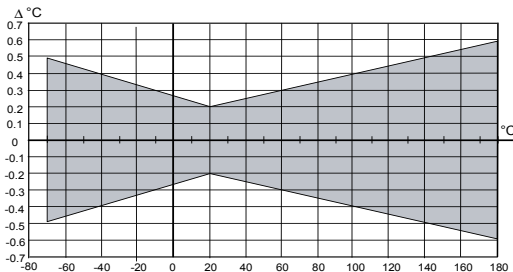

Electronics

Cable feed through alternatives	8-pole connector with 5 m cable, Female 8-pin connector screw joint for cable diameter 4 ... 8 mm
Operating voltage	12 ... 35 VDC, the maximum operating voltage for a device with sensor heating is 24 VDC
Power consumption	30 mA with RS-232
Startup time after powerup	3 s

General

Operating temperature range for electronics	-40 ... +60 °C (-40 ... +140 °F)
Storage temperature range	-55 ... +80 °C (-67 ... +176 °C)
Transmitter housing material	G-AlSi10Mg
Transmitter base material	ABS/PC
Housing classification	IP65
Sensor protection	PPS grid with stainless steel net, PPS grid, Sintered filter, Membrane stainless steel filter, Stainless steel grid

Dimensions

Transmitter HMT317

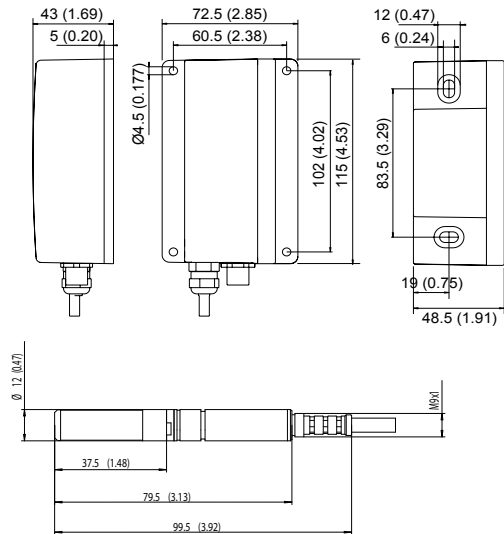

For more information, visit www.vaisala.com or contact us at sales@vaisala.com

Ref. B210769EN-B ©Vaisala 2009

This material is subject to copyright protection, with all copyrights retained by Vaisala and its individual partners. All rights reserved. Any logos and/or product names are trademarks of Vaisala or its individual partners. The reproduction, transfer, distribution or storage of information contained in this brochure in any form without the prior written consent of Vaisala is strictly prohibited. All specifications — technical included — are subject to change without notice.

